

TRACK

SIZE: OPEN MEDIUM TIGHT
 TRACTION: HIGH MEDIUM LOW
 SURFACE: SMOOTH MEDIUM BUMPY
 TYPE: HARD PACKED SOFT DIRT CLAY
 BLUE GROOVE ASTRO TURF GRASS
 CONDITION: DRY DUSTY WET MUD
 TEMPRATURE: AIR: _____ TRACK: _____

DIFFERENTIALS

| FRONT | | | CENTER | | | REAR | | |
|--------------------------|--------------------------|--------------------------|--------------------------|--------------------------|--------------------------|--------------------------|--------------------------|--------------------------|
| LSD | OPEN | OD | LSD | SOLID | | LSD | OPEN | |
| <input type="checkbox"/> | <input type="checkbox"/> | <input type="checkbox"/> | <input type="checkbox"/> | <input type="checkbox"/> | | <input type="checkbox"/> | <input type="checkbox"/> | |
| LSD Ramp | | | LSD Ramp | | | LSD Ramp | | |
| 60° | 90° | 120° | 60° | 90° | 120° | 60° | 90° | 120° |
| <input type="checkbox"/> | <input type="checkbox"/> | <input type="checkbox"/> | <input type="checkbox"/> | <input type="checkbox"/> | <input type="checkbox"/> | <input type="checkbox"/> | <input type="checkbox"/> | <input type="checkbox"/> |

SHOCK SPRINGS

| FRONT | REAR |
|--------------------------|--------------------------|
| <input type="checkbox"/> | <input type="checkbox"/> |
| <input type="checkbox"/> | <input type="checkbox"/> |
| <input type="checkbox"/> | <input type="checkbox"/> |
| <input type="checkbox"/> | <input type="checkbox"/> |
| <input type="checkbox"/> | <input type="checkbox"/> |
| <input type="checkbox"/> | <input type="checkbox"/> |
| <input type="checkbox"/> | <input type="checkbox"/> |
| <input type="checkbox"/> | <input type="checkbox"/> |
| <input type="checkbox"/> | <input type="checkbox"/> |

OIL VISCOSITY

FRONT _____ REAR _____

PISTON HOLE SIZES

| FRONT | REAR |
|--|--|
| 2x2mm <input type="checkbox"/> 4x2mm <input type="checkbox"/> 3x2mm <input type="checkbox"/> 5x2mm <input type="checkbox"/> | 2x2mm <input type="checkbox"/> 4x2mm <input type="checkbox"/> 3x2mm <input type="checkbox"/> 5x2mm <input type="checkbox"/> |

ACKERMAN

LESS STANDARD

ANTI-ROLL BAR

FRONT THICKNESS REAR

CHASSIS

BODY

LONG SHORT

NOTES

www.mcdracing.com/support

POSITION: _____ BEST LAP: _____

NAME: _____

RACE: _____ DATE: _____/_____/_____

RR5 & RR5-MAX ULTIMATE SET-UP SHEET

www.MCDRACING.com

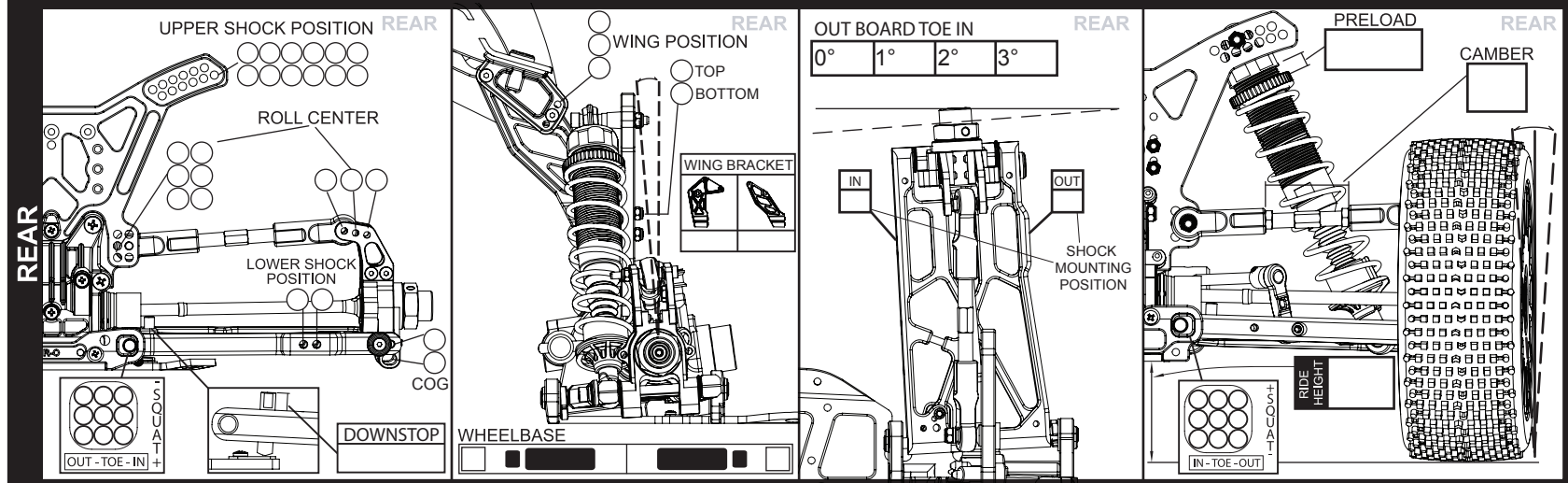
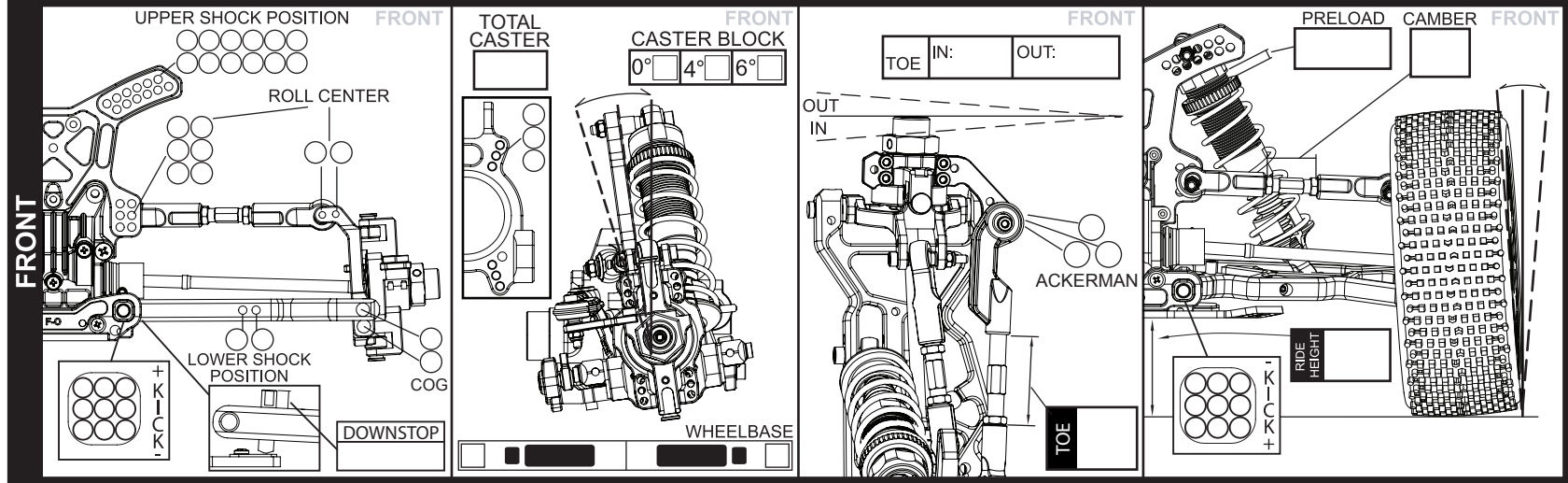

TYRES

| | | |
|------------|----------------------------|----------------------------|
| | F | R |
| Micro-Stud | <input type="checkbox"/> | <input type="checkbox"/> |
| Block-Stud | <input type="checkbox"/> | <input type="checkbox"/> |
| Micro-Stud | <input type="checkbox"/> | <input type="checkbox"/> |
| Astro-Grip | <input type="checkbox"/> | <input type="checkbox"/> |
| Dirt-Max | <input type="checkbox"/> | <input type="checkbox"/> |
| Astro-Max | <input type="checkbox"/> | <input type="checkbox"/> |
| OTHER: | <input type="checkbox"/> | <input type="checkbox"/> |
| COMPOUND | F <input type="checkbox"/> | R <input type="checkbox"/> |
| INSERT | F <input type="checkbox"/> | R <input type="checkbox"/> |

POWER UNIT

ENGINE: _____

CARBURATOR: _____

PLUG: _____

OIL: _____

CLUTCH: _____

PIPE: _____

TRANSMISSION RATIO

| Final Ratio | Engine | Center Diff |
|-------------|--------|-------------|
| 6,92 | 26 | 60 |
| 7,20 | 25 | 60 |
| 7,44 | 25 | 62 |
| 7,50 | 24 | 60 |
| 7,75 | 24 | 62 |
| 7,83 | 23 | 60 |
| 7,88 | 24 | 63 |
| 8,09 | 23 | 62 |
| 8,18 | 22 | 60 |
| 8,22 | 23 | 63 |
| 8,35 | 23 | 64 |
| 8,45 | 22 | 62 |
| 8,59 | 22 | 63 |
| 8,73 | 22 | 64 |
| 8,86 | 21 | 62 |
| 8,86 | 22 | 65 |
| 9,00 | 21 | 63 |
| 9,14 | 21 | 64 |
| 9,29 | 21 | 65 |
| 9,30 | 20 | 62 |
| 9,45 | 20 | 63 |
| 9,60 | 20 | 64 |
| 9,75 | 20 | 65 |
| 9,95 | 19 | 63 |
| 10,11 | 19 | 64 |